Mini-PROTEAN[®] 3 Cell

Instruction Manual

Catalog Numbers

165-3301

165-3302



Table of Contents

	Page
Section 1 General Information.....	1
1.1 Introduction	1
1.2 Components.....	2
1.3 Specifications	4
1.4 Chemical Compatibility	4
1.5 Safety	5
Section 2 Set Up and Basic Operation.....	5
2.1 Gel Cassette Preparation	5
2.2 Mini-PROTEAN 3 Cell Assembly and Sample Loading	8
2.3 Gel Electrophoresis	9
Section 3 Separation Theory and Optimization.....	10
3.1 Introduction	10
3.2 SDS-PAGE (Laemmli) Buffer System.....	11
3.3 Native PAGE.....	12
Section 4 Reagent Preparation and Stock Solutions	13
4.1 Volumes Required Per Gel	13
4.2 SDS-PAGE (Laemmli) Buffer System.....	13
4.3 Discontinuous Native PAGE (Ornstein-Davis).....	15
4.4 Continuous Native PAGE	16
Section 5 References	18
Section 6 Maintenance	18
Section 7 Troubleshooting.....	19
Section 8 Product Information and Accessories	21
Section 9 Warranty Information.....	23

Section 1 General Information

1.1 Introduction

The Mini-PROTEAN 3 cell runs both hand cast gels and Ready Gel precast gels interchangeably. The Mini-PROTEAN 3 system includes a casting stand and glass plates with permanently bonded gel spacers that simplify hand casting and eliminate leaking during casting. The cell can run one or two gels, and the mini tank is compatible with other Bio-Rad electrode modules for tank blotting, 2-D electrophoresis, and electro-elution.

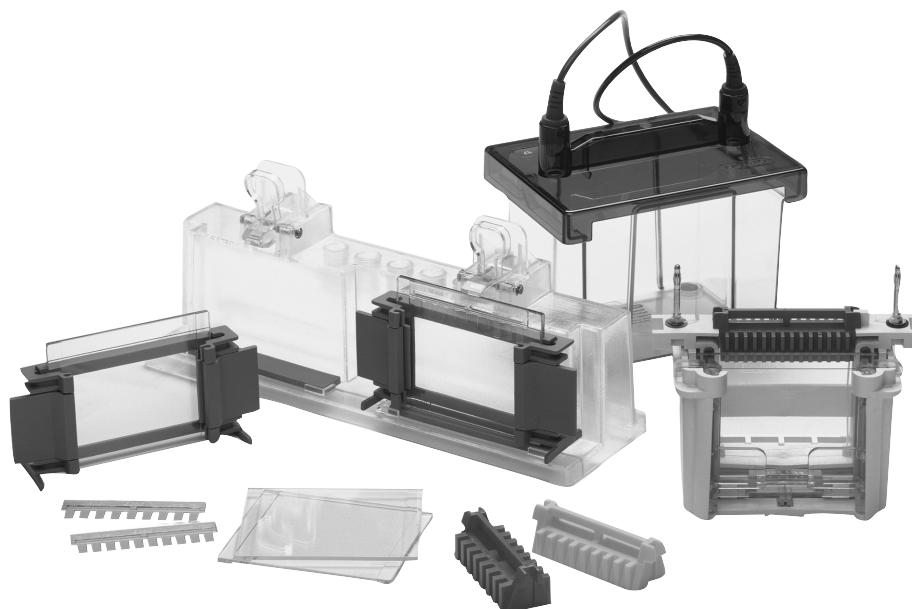

Fig. 1. Mini-PROTEAN 3 system components.

1.2 Components

To get the best performance from your Mini-PROTEAN 3 cell, familiarize yourself with the components by assembling and disassembling the cell before using it (refer to Figures 1 and 2).

Spacer Plate	The Spacer Plate is the taller glass plate with gel spacers permanently bonded. Spacer Plates are available in 0.5 mm, 0.75 mm, 1.0 mm, and 1.5 mm thicknesses, which are marked directly on each Spacer Plate.
Short Plate	The Short Plate is the shorter, flat glass plate that combines with the Spacer Plate to form the gel cassette sandwich.
Casting Frame	The Casting Frame, when placed on the benchtop, evenly aligns and secures the Spacer Plate and the Short Plate together to form the gel cassette sandwich prior to casting.
Gel Cassette Assembly	One Casting Frame, a Spacer Plate, and a Short Plate form one Gel Cassette Assembly.
Casting Stand	The Casting Stand secures the Gel Cassette Assembly during gel casting. It contains pressure levers that seal the Gel Cassette Assembly against the casting gaskets.
Gel Cassette Sandwich	A Spacer Plate and Short Plate with polymerized gel form a Gel Cassette Sandwich after casting.
Combs	A selection of molded combs is available.
Buffer Dam	The molded, one-piece buffer dam is used when running only one gel.
Electrode Assembly	The Electrode Assembly holds the Gel Cassette Sandwich. It houses the sealing gasket, the upper and lower electrodes and the connecting banana plugs. The anode (lower electrode) banana plug is identified with a red marker and the cathode (upper electrode) banana plug with a black marker.
Clamping Frame	The Clamping Frame holds the Electrode Assembly and Gel Cassette Sandwich in place. Its pressure plates and closure cams seal the Gel Cassette Sandwich against U-shaped gaskets on the Electrode Assembly to form the inner buffer chamber.
Inner Chamber	The Electrode Assembly, two Gel Cassette Sandwiches or one gel cassette sandwich and a buffer dam, and the Clamping Frame form the Inner Chamber.
Mini Tank and Lid	The Mini Tank and Lid combine to fully enclose the inner chamber during electrophoresis. The lid cannot be removed without disrupting the electrical circuit. The Mini Tank and Lid are also compatible with other Bio-Rad electrode modules for blotting, first dimension 2-D, and electro-elution.

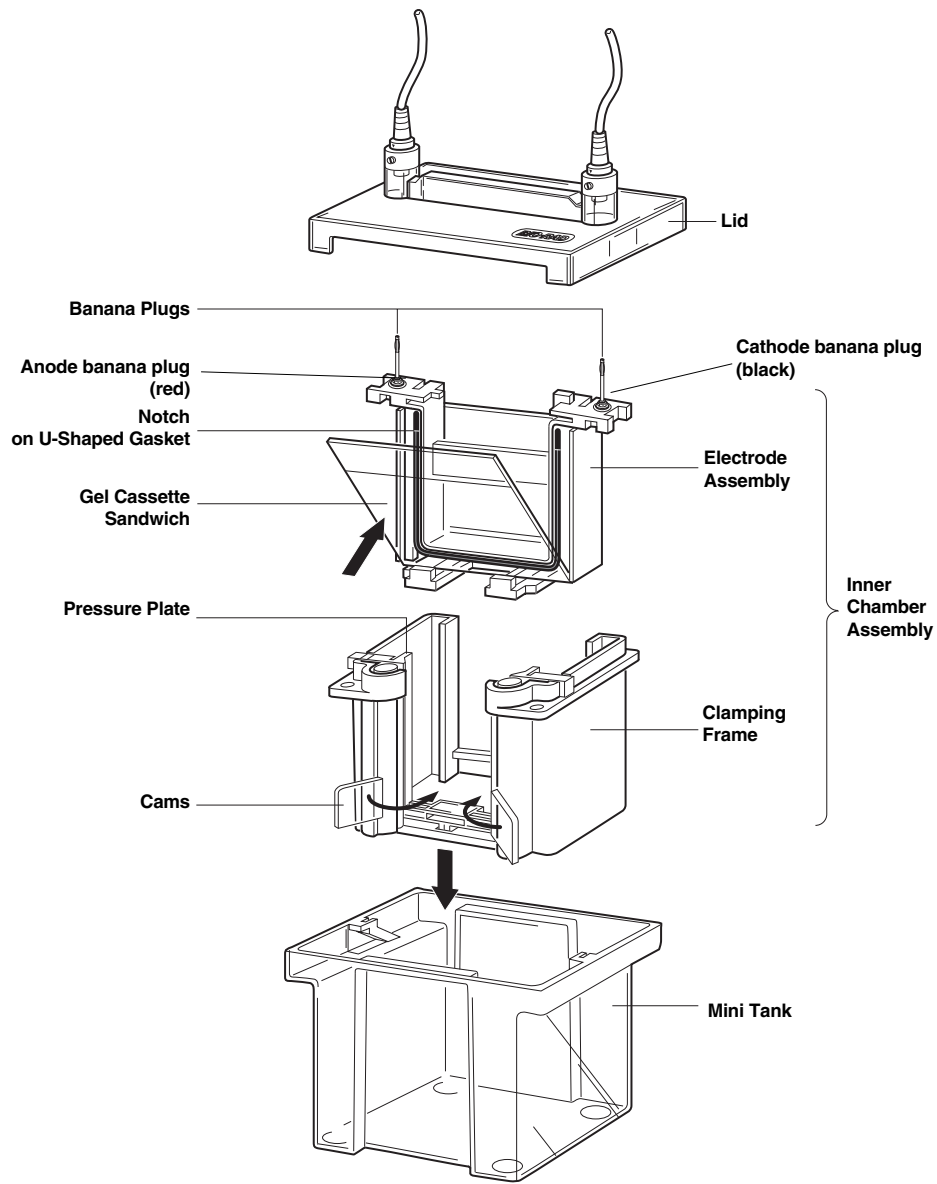

Fig. 2. Assembling the Mini-PROTEAN 3 cell.

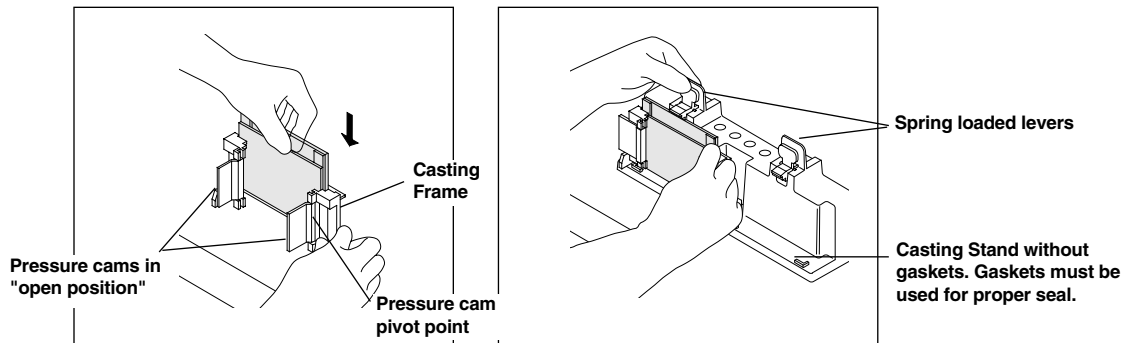

Fig. 3. Assembling the Mini-PROTEAN 3 Casting Frame and Casting Stand.

1.3 Specifications

Casting Stand*	Polycarbonate
Pin, Retaining Ring, and Spring	Stainless Steel
Casting Frames*	Polysulfone
Gray Gaskets	Silicone Rubber (gray)
Clamping Frame**	Glass-filled liquid crystal polymer (Vectra™)
Pressure Plate and Cams	Polycarbonate
Electrode Assembly	Glass-filled liquid crystal polymer
Electrodes	Platinum wire, 0.010 inches diameter
Gasket, electrode inner core	Silicone Rubber (green)
Mini Tank and Lid	Molded Polycarbonate
Sample Loading Guides†	Delrin™
Combs*	Polycarbonate

Maximum Sample Volume Per Well

# wells	Well width	0.5 mm	0.75 mm	1.0 mm	1.5 mm
5	12.7 mm	—	70 µl	105 µl	160 µl
9	5.08 mm	—	33 µl	44 µl	66 µl
10	5.08 mm	22 µl	33 µl	44 µl	66 µl
15	3.35 mm	13 µl	20 µl	26 µl	40 µl
IPG	76.2 mm	—	—	420 µl	730 µl
Prep/2-D					
Reference well	3.1 mm	—	13 µl	17 µl	30 µl
Sample well	71.7 mm	—	310 µl	400 µl	680 µl

Overall Size of cell	16 cm (L) x 12 cm (W) x 18 cm (H)
Gel Size	8 cm (W) x 7.3 cm (H)
Inner Plate	10.1 cm (W) x 7.3 cm (H)
Outer Plater	10.1 cm (W) x 8.3 cm (H)
Precast Gel Compatibility	Ready Gels
Voltage Limit	600 VDC and 15 watts
Shipping Weight	2.0 kg

1.4 Chemical Compatibility

Mini-PROTEAN 3 components are not compatible with acetone, ethanol, or butanol. Use of organic solvents voids all warranties. Call 1-800-4-BIORAD or your local Bio-Rad representative for technical information regarding additional chemical compatibility of the Mini-PROTEAN 3 cell with various laboratory reagents.

The Mini-PROTEAN 3 combs are not compatible with repeated exposure to 100% TEMED. Rubbing the combs with TEMED prior to casting will destroy the structural integrity of the combs over time.

* US patent No. 6,162,342

** US patent No. 5,632,877

† US patent No. 5,656,145

1.5 Safety

Power to the Mini-PROTEAN 3 cell is supplied by an external DC voltage power supply (not included). The output of this power supply must be isolated from external ground to insure that the DC voltage output floats with respect to ground. All Bio-Rad power supplies meet this important safety requirement. Regardless of the power supply used, the maximum specified operating parameters for the Mini-PROTEAN 3 cell are as follows:

- 600 VDC maximum voltage limit
- 15 watts maximum power limit
- 50 °C maximum ambient temperature limit

The current to the cell enters the unit through the lid assembly which provides a safety interlock to the user. The current to the cell is broken when the lid is removed. Always turn off the power supply before removing the lid. **Do not attempt to use the cell without the safety lid.**

Important: This Bio-Rad product is designed and certified to meet *EN61010-1 safety standards. Certified products are safe to use when operated in accordance with the instruction manual. This instrument should not be modified or altered in any way. Alteration of this instrument will

- Void the warranty
- Void the EN61010-1 certification, and
- Create a potential safety hazard.

Bio-Rad is not responsible for any injury or damage caused by use of this instrument for purposes other than those for which it is intended or by modifications of the instrument not performed by Bio-Rad or an authorized agent.

*EN61010-1 is an internationally accepted electrical safety standard for laboratory instruments.

Section 2 Set Up and Basic Operation

2.1 Gel Cassette Sandwich Preparation

Hand Cast Gels

1. Glass Cassette and Casting Stand Assembly

Note: Ensure the casting stand, casting frames, and glass plates are clean and dry before setting up the casting stand assembly. During regular use, a powder residue may build up behind the pressure cams of the casting frame at the pivot point. This powder should be removed before each use.

- a. Place the Casting Frame upright with the pressure cams in the open position and facing forward on a flat surface.
- b. Select a Spacer Plate of the desired gel thickness and place a Short Plate on top of it (see Figure 4a).
- c. Orient the Spacer Plate so that the labeling is "up". Slide the two glass plates into the Casting Frame, keeping the Short Plate facing the front of the frame (side with pressure cams) (see Figure 4b).

Note: Ensure both plates are flush on a level surface and labeling on the Spacer Plate is oriented correctly. Leaking may occur if the plates are misaligned or oriented incorrectly.

- d. When the glass plates are in place, engage the pressure cams to secure the glass cassette sandwich in the Casting Frame (see Figure 4c). Check that both plates are flush at the bottom.

- e. Engage the spring loaded lever and place the gel cassette assembly on the gray casting stand gasket. Insure the horizontal ribs on the back of the Casting Frame are flush against the face of the Casting Stand and the glass plates are perpendicular to the level surface. The lever pushes the Spacer Place down against the gray rubber gasket (see Figure 4d).
- f. Repeat steps a–e for a second gel.

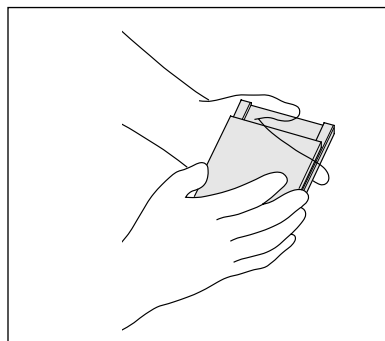

4a. Place a Short Plate on top of the Spacer Plate.

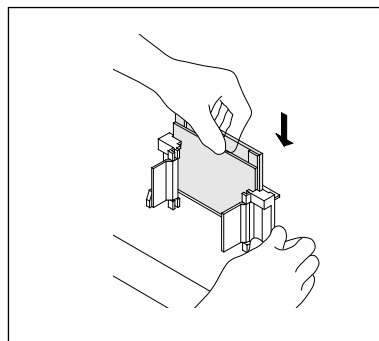

4b. Slide the two plates into the Casting Frame keeping the Short Plate facing front.

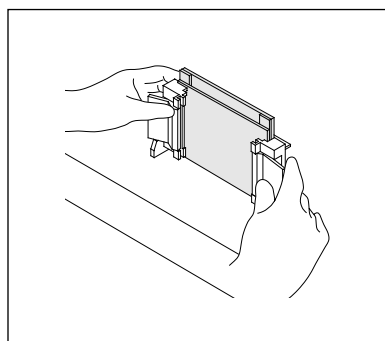

4c. Lock the pressure cams to secure the glass plates.

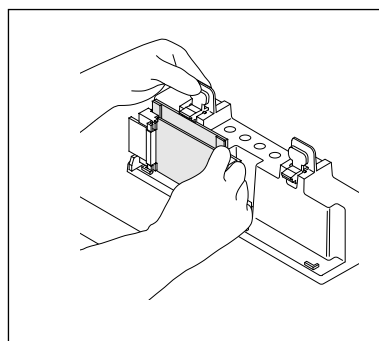

4d. Secure the Casting Frame in the Casting Stand by engaging the spring loaded lever.

Fig. 4. Assembling the Mini-PROTEAN 3 casting stand and frame.

2. Gel Casting

a. Discontinuous Polyacrylamide Gels

- i. Place a comb completely into the assembled gel cassette. Mark the glass plate 1 cm below the comb teeth. This is the level to which the resolving gel is poured. Remove the comb.
- ii. Prepare the resolving gel monomer solution by combining all reagents except APS and TEMED. (Refer to Section 4 for gel formulations.) Degas the solution under vacuum for at least 15 minutes. Do not use a sink water aspirator.
- iii. Add APS and TEMED to the degassed monomer solution and pour to the mark using a glass or disposable plastic pipette. Pour the solution smoothly to prevent it from mixing with air.
- iv. Immediately overlay the monomer solution with water or t-amyl alcohol.

Note: If water is used, add it slowly and evenly to prevent mixing. **Do not overlay w/butanol or isobutanol.**

- v. Allow the gel to polymerize for 45 minutes to 1 hour. Rinse the gel surface completely with distilled water. Do not leave the alcohol overlay on the gel for more than 1 hour because it will dehydrate the top of the gel.

Note: At this point the resolving gel can be stored at room temperature overnight. Add 5 ml of a 1:4 dilution of 1.5 M Tris-HCl, pH 8.8 buffer (for Laemmli System) to the resolving gel to keep it hydrated. If using another buffer system, add 5 ml 1x resolving gel buffer to the resolving gel surface for storage.

- vi. Prepare the stacking gel monomer solution. Combine all reagents except APS and TEMED. Degas under vacuum for at least 15 minutes.
 - vii. Before casting the stacking gel, insert a piece of filter paper to dry the area in between the glass plates above the resolving gel. Take care not to touch the surface of the gel.
 - viii. Add APS and TEMED to the degassed stacking gel monomer solution and pour the solution between the glass plates. Continue to pour until the top of the short plate is reached.
 - ix. Insert the desired comb between the spacers starting at the top of the Spacer Plate, making sure that the tabs at the ends of each comb are guided between the spacers. It is easiest to insert the combs starting at an angle and insert well 1 first, then 2, 3, and so on until the combs is completely inserted. Seat the comb in the gel cassette by aligning the comb ridge with the top of the Short Plate.
 - x. Allow the stacking gel to polymerize for 30–45 minutes.
 - xi. Gently remove the comb and rinse the wells thoroughly with distilled water or running buffer.
 - xii. Rinse the Casting Frame(s) and Stand with distilled, deionized water after use.
- b. **Continuous Polyacrylamide Gels**
- i. Prepare the monomer solution by combining all reagents except the APS and the TEMED. Degas under vacuum for 15 minutes (Refer to Section 4 for gel formulations).
 - ii. Add APS and TEMED to the degassed monomer solution and pour the solution between the glass plates. Continue to pour until the top of the Short Plate is reached.
 - iii. Insert the desired comb between the spacers starting at the top of the Spacer Plate, making sure that the tabs at the ends of each comb are guided between the spacers. It is easiest to insert the combs starting at an angle and insert well 1 first, then 2, 3, and so on until the combs is completely inserted. Seat the comb in the gel cassette by aligning the comb ridge with the top of the Short Plate.
 - iv. Allow the gel to polymerize for 45 minutes to 1 hour.
 - v. Gently remove the comb and rinse the wells thoroughly with distilled water or running buffer.
 - vi. Rinse the Casting Frame(s) and Stand with distilled, deionized water after use.

Ready Gel Precast Gels

1. Ready Gel Cassette Preparation

Note: The Mini-PROTEAN 3 cell is guaranteed for use only with Bio-Rad's Ready Gel precast gels.

- a. Remove the Ready Gel from the storage pouch.
- b. Gently remove the comb and rinse the wells thoroughly with distilled water or running buffer.
- c. Cut along the dotted line at the bottom of the Ready Gel Cassette with a razor blade.
- d. Pull the clear tape at the bottom of the Ready Gel Cassette to expose the bottom edge of the gel.
- e. Repeat for second Ready Gel.

Note: If only one gel is to be run, use the mini cell buffer dam.

2.2 Mini-PROTEAN 3 Electrophoresis Module Assembly and Sample Loading

Mini-PROTEAN 3 Electrophoresis Module Assembly

1. Remove the Gel Cassette Assemblies from the Casting Stand. Rotate the cams of the Casting Frames inward to release the Gel Cassette Sandwich (see Figure 5a).
2. Place a Gel Cassette Sandwich into the slots at the bottom of each side of the Electrode Assembly. Be sure the Short Plate of the Gel Cassette Sandwich faces inward toward the notches of the U-shaped gaskets (see Figure 5b).
3. Lift the Gel Cassette Sandwich into place against the green gaskets and slide into the Clamping Frame (see Figure 5c).
4. Press down on the Electrode Assembly while closing the two cam levers of the Clamping Frame to form the Inner Chamber and to insure a proper seal of the short plate against the notch on the U-shaped gasket. (see Figure 5d). Short plate must align with notch in gasket.

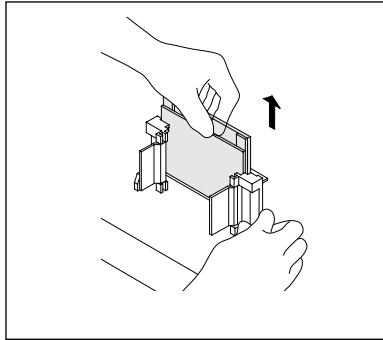

5a. Remove the Gel Cassette Sandwich from the Casting Frame.

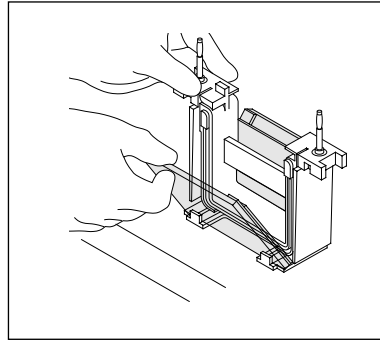

5b. Place Gel Cassette Sandwich into the Electrode Assembly with the Short Plate facing inward.

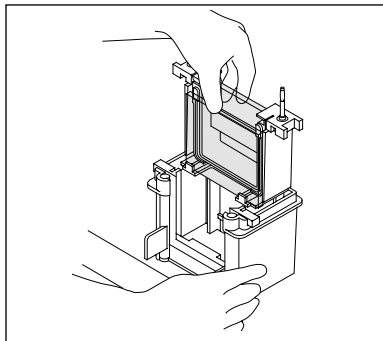

5c. Slide Gel Cassette Sandwiches and Electrode Assembly into the clamping frame.

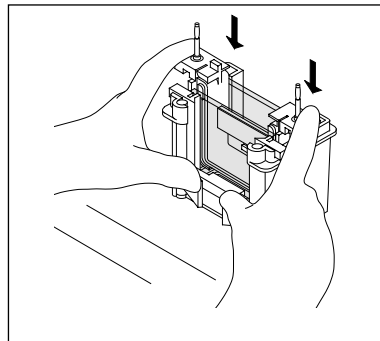

5d. Press down on the Electrode Assembly while closing the two cam levers of the Clamping Frame.

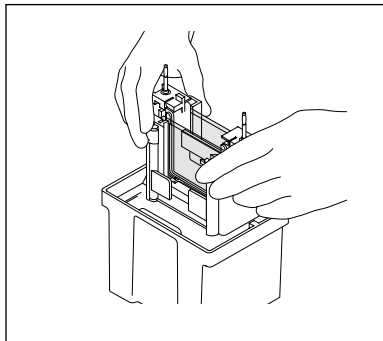

5e. Lower the Inner Chamber into the Mini Tank.

Fig. 5. Mini-PROTEAN 3 assembly.

Note: Gently pressing the top of the Electrode Assembly while closing the Clamping Frame cams forces the top of the Short Plate on each Gel Cassette Sandwich to seat against the rubber gasket properly and prevents leaking.

5. Lower the Inner Chamber Assembly into the Mini Tank. Fill the inner chamber with ~125 ml of running buffer until the level reaches halfway between the tops of the taller and shorter glass plates of the Gel Cassettes.

Note: Do not overfill the Inner Chamber Assembly. Excess buffer will cause the siphoning of buffer into the lower chamber which can result in buffer loss and interruption of electrophoresis.

6. Add ~200 ml of running buffer to the Mini Tank (lower buffer chamber).

Sample Loading

1. Load the samples into the wells with a Hamilton syringe or a pipette using gel loading tips.
2. If using Bio-Rad's patented sample loading guide, place it between the two gels in the Electrode Assembly. Sample loading guides are available for 9, 10, 12, and 15 well formats.

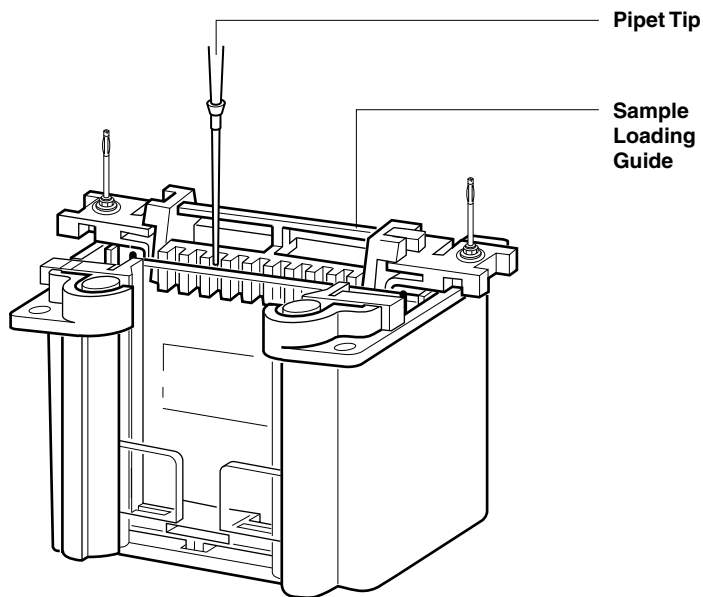

Fig. 6. Using the Sample Loading Guide (patent #5,656,145).

3. Use the Sample Loading Guide to locate the sample wells. Insert the Hamilton syringe or pipette tip into the slots of the guide and fill the corresponding wells.

Note: Load samples slowly to allow them to settle evenly on the bottom of the well. Be careful not to puncture the bottom of the well with the syringe needle or pipette tip.

2.3 Gel Electrophoresis

Mini Tank Assembly

1. Place the Lid on the Mini Tank. Make sure to align the color coded banana plugs and jacks. The correct orientation is made by matching the jacks on the lid with the banana plugs on the electrode assembly. A stop on the lid prevents incorrect orientation.

Power Conditions

1. Insert the electrical leads into a suitable power supply with the proper polarity.
2. Apply power to the Mini-PROTEAN 3 cell and begin electrophoresis; 200 volts constant is recommended for SDS-PAGE and most native gel applications. Run time is approximately 35 minutes at 200 volts for SDS-PAGE.

Gel Removal

1. After electrophoresis is complete, turn off the power supply and disconnect the electrical leads.
2. Remove the tank lid and carefully lift out the Inner Chamber Assembly. Pour off and discard the running buffer.

Note: Always pour off the buffer before opening the cams to avoid spilling the buffer.

3. Open the cams of the Clamping Frame. Pull the Electrode Assembly out of the Clamping Frame and remove the Gel Cassette Sandwiches.
4. Remove the gels from the Gel Cassette Sandwich by gently separating the two plates of the gel cassette. The green, wedgeshaped, plastic Gel Releaser may be used to help pry the glass plates apart.

Note: To remove the gel from a Ready Gel Cassette, first slice the tape along the sides of the Ready Gel Cassette where the inner glass plate meets the outer plastic plate.

5. Run the sharp edge of the Gel Releaser or a razor blade along each spacer to separate the gel from the spacer. Remove the gel by floating it off the glass plate by inverting the gel and plate under fixative or transfer solution, agitating gently until the gel separates from the plate.
6. Rinse the Mini-PROTEAN 3 cell electrode assembly, Clamping Frame and Mini Tank with distilled, deionized water after use.

Section 3 Separation Theory and Optimization

3.1 Introduction

Polyacrylamide gel electrophoresis separates molecules in complex mixtures according to size and charge. During electrophoresis there is an intricate interaction of samples, gel matrix buffers, and electric current resulting in separate bands of individual molecules. Hence the variables that must be considered in electrophoresis are gel pore size, gel buffer systems, and the properties of the molecule of interest.

Gel Pore Size

Gel pores are created by the crosslinking of polyacrylamide with bis-acrylamide (bis) to create a network of pores. This structure allows the molecular sieving of molecules through the gel matrix. Gel pore size is a function of the acrylamide monomer concentration used (%T). By convention, polyacrylamide gels are characterized by %T which is the weight percentage of the total monomer including the crosslinker. The %T gives an indication of the relative pore size of the gel. In general, pore size decreases with increasing %T.

%T is calculated using the following equation.

$$\%T = \frac{\text{g acrylamide} + \text{g crosslinker}}{\text{total volume (ml)}} \times 100\%$$

%C is the crosslinker:acrylamide monomer ratio of the monomer solution. %C is calculated using the following equation.

$$\%C = \frac{\text{g crosslinker} \times 100\%}{\text{g acrylamide} + \text{g crosslinker}}$$

2.67% C is traditionally used for most analytical gels.

Gels can be made as a single continuous percentage throughout the gel, or can be cast as a gradient %T through the gel. Typical compositions are from 7.5% up to 20% for single percentage gels, or gradients ranging from 4–15% to 10–20%.

The total monomer concentration for optimal separation is referred to as optimal %T. Optimal %T will vary depending on the molecular weight of the molecule of interest. Empirically the pore size providing optimum resolution for proteins is that which results in a relative mobility (R_f) value between 0.55–0.6. R_f values for specific proteins are calculated as follows.

$$R_f = \frac{\text{Distance migrated by the protein of interest}}{\text{Distance migrated by the ion front}}$$

Gel Buffer System

The buffer system determines the power requirements and affects separation. The buffer system is composed of the buffer used in the gel and the running buffer. There are continuous and discontinuous buffer systems.

Continuous Buffer Systems

In continuous buffer systems the same buffer ions are present, at constant pH and concentration throughout the system. The gel is typically made of one continuous %T and the sample is loaded directly into the part of the gel where separation will occur. The band width is determined in part by the height of the sample load in the well, so samples should be concentrated and volumes small for best results.

Discontinuous Buffer Systems

In discontinuous buffer systems different buffer ions are present in the gel and electrode reservoirs. By using different buffers in the gel and in the electrode solutions and adding a stacking gel to the resolving gel, samples are compressed into a thin starting band and individual proteins are finely resolved and separated. Discontinuous buffer systems were devised initially for use with undenatured, or native proteins; however the most popular discontinuous system employed is the SDS-PAGE buffer system by Laemmli.¹ Formulations for this system are included in Section 4.1.

3.2 SDS-PAGE (Laemmli) Buffer System

The Laemmli buffer system is a discontinuous buffer system that incorporates SDS in the buffer. In this system, proteins are denatured by heating them in buffer containing sodium dodecyl sulfate (SDS) and a thiol reducing agent such as 2-mercaptoethanol (β ME.) The resultant polypeptides take on a rod-like shape and a uniform charge-to-mass ratio proportional to their molecular weights. Proteins separate according to their molecular weight, making this system extremely useful for calculating molecular weights.

3.3 Native PAGE

Native PAGE is a technique for separating biologically active proteins. In contrast to SDS-PAGE, the mobilities of proteins in a Native PAGE system depend on both size and charge. There is no single electrophoresis buffer system that will optimally separate all proteins in a native gel. Key parameters for separating proteins in a Native PAGE system are pI of the protein of interest and the pH of the electrophoresis buffer

pH and pI

The pH of the electrophoresis buffer must be within the pH range over which the protein of interest is stable and retains biological activity. In addition, the pH of the buffer must impart sufficient charge to the protein for it to move through the gel. Changes in pH will affect both the charge and size (hydrodynamic volume) of the protein of interest and will affect migration rates. For example, a buffer with a pH greater than the pI of the protein will impart a negative charge on the protein and it will migrate toward the positive electrode (anode). Conversely, a buffer with a pH lower than the pI of the protein will impart a positive charge and the protein will migrate to the negative electrode (cathode). A pH equal to the pI will result in no net charge in the protein and it will not migrate in an electric field.

Protein mobilities are best modified by the buffer's pH. Buffers with a pH closer to the pI will provide the best resolution. However run times may be lengthy. Conversely, buffers with a pH further from the pI will allow faster migration but resolution may be compromised. The choice of pH becomes a tradeoff between separation and speed.

How to Choose a Native PAGE system

1. Discontinuous Buffer Systems (Ornstein-Davis²)

A discontinuous buffer system should be the first non-denaturing gel system tried. Detailed protocols are provided in Section 4.2. The advantage of a discontinuous system is the use of a stacking gel to concentrate dilute protein samples. However, the stacking phenomena can also cause aggregation of some proteins and interfere with resolution. If protein aggregation occurs, a continuous buffer system should be used.

Note: The pH attained in the resolving gel of the Ornstein-Davis system approaches pH 9.5, which may be outside the range of stability for some proteins, causing denaturation. Additionally, the pI of the protein of interest may be too close to or above the Ornstein-Davis buffer pH (9.5), which may result in a very low net charge or a positive net charge that may significantly reduce or even prohibit migration to the anode. Alternative discontinuous systems can be found in an article by Chrumbach and Jovin.³

Note: It is very desirable to know the pI of the protein of interest before selecting a buffer system.

2. Continuous Buffer Systems

A continuous buffer system will be required if discontinuous systems cannot be used due to stacking-induced protein aggregation. In a continuous system the same buffer is used in the upper and lower electrode chambers as in the gel. Since stacking does not occur, proteins migrate in bands at least as wide as the height of the applied sample in the well. Consequently, sample volumes should be minimized. The mobility of proteins in a continuous system is dictated by pH rather than by sieving through the polyacrylamide gel. For this reason, 6% polyacrylamide gels are recommended for most applications. For very large proteins, 4% or 5% gels may be used. McLellan describes various continuous buffer systems from pH 3.8–10.2.⁴ Detailed protocols are provided in Section 4.3.

Section 4

Reagent Preparation and Stock Solutions

4.1 Volumes Required Per Gel

The volumes listed are required to completely fill a gel cassette. Amounts may be adjusted depending on the application (with or without comb, with or without stacking gel, etc.).

Gel Thickness (mm)	Volume (ml)
0.5	2.8
0.75	4.2
1.0	5.6
1.5	8.4

Note: 10 ml of monomer solution is sufficient for two stacking gels of any thickness.

4.2 SDS-PAGE (Laemmli)¹ Buffer System

Stock Solutions and Buffers

1. Acrylamide/Bis (30% T, 2.67% C)

87.6 g	acrylamide	(29.2 g/100 ml)
2.4 g	N'N'-bis-methylene-acrylamide	(0.8 g/100 ml)

Make to 300 ml with deionized water. Filter and store at 4 °C in the dark (30 days maximum.)

or, use:

Prewighed Acrylamide/Bis, 37.5:1 mixture (30%T, 2.67% C)
(Bio-Rad catalog number 161-0125, 150 g)

30% Acrylamide/Bis Solutions, 37.5:1 mixture (30%T, 2.67% C)
(Bio-Rad catalog number 161-0158, 500 ml)
(Bio-Rad catalog number 161-0159, 2 x 500 ml)

2. 10% (w/v) SDS

Dissolve 10 g SDS in 90 ml water with gentle stirring and bring to 100 ml with deionized water. Alternatively 10% SDS solution (250 ml) can be used (Bio-Rad catalog number 161-0416).

3. 1.5 M Tris-HCl, pH 8.8

27.23 g	Tris base	(18.15 g/100 ml)
80 ml	deionized water	

Adjust to pH 8.8 with 6 N HCl. Bring total volume to 150 ml with deionized water and store at 4 °C. Alternatively 1.5 M Tris-HCl, pH 8.8 (1 L) premixed buffer can be used (Bio-Rad catalog number 161-0798).

4. 0.5 M Tris-HCl, pH 6.8

6 g	Tris base
60 ml	deionized water

Adjust to pH 6.8 with 6 N HCl. Bring total volume to 100 ml with deionized water and store at 4 °C. Alternatively 0.5 M Tris-HCl, pH 6.8 (1 L) premixed buffer can be used (Bio-Rad catalog number 161-0799).

5. Sample Buffer (SDS Reducing Buffer)

3.55 ml	deionized water
1.25 ml	0.5 M Tris-HCl, pH 6.8
2.5 ml	glycerol
2.0 ml	10% (w/v) SDS
<u>0.2 ml</u>	<u>0.5% (w/v) bromophenol blue</u>
9.5 ml	Total Volume

Store at room temperature.

Use: Add 50 µl β-Mercaptoethanol to 950 µl sample buffer prior to use. Dilute the sample at least 1:2 with sample buffer and heat at 95 °C for 4 minutes.

6. 10x Electrode (Running) Buffer, pH 8.3 (makes 1 L)

30.3 g	Tris base
144.0 g	Glycine
10.0 g	SDS

Dissolve and bring total volume up to 1,000 ml with deionized water. Do not adjust pH with acid or base. Store at 4 °C. If precipitation occurs, warm to room temperature before use. Alternatively, electrophoresis running buffer 10x Tris/Glycine/SDS, 5 L cube (Bio-Rad catalog number 161-0772) can be used.

Use: Dilute 50 ml of 10x stock with 450 ml deionized water for each electrophoresis run. Mix thoroughly before use.

7. 10% APS (fresh daily)

100 mg ammonium persulfate
Dissolved in 1 ml of deionized water.

Gel Formulations (10 ml)

1. Prepare the monomer solution by mixing all reagents except the TEMED and 10% APS. Degas the mixture for 15 minutes.

Percent Gel	DDI H ₂ O (ml)	30% Degassed		
		Acrylamide/Bis (ml)	*Gel Buffer (ml)	10% w/v SDS (ml)
4%	6.1	1.3	2.5	0.1
5%	5.7	1.7	2.5	0.1
6%	5.4	2.0	2.5	0.1
7%	5.1	2.3	2.5	0.1
8%	4.7	2.7	2.5	0.1
9%	4.4	3.0	2.5	0.1
10%	4.1	3.3	2.5	0.1
11%	3.7	3.7	2.5	0.1
12%	3.4	4.0	2.5	0.1
13%	3.1	4.3	2.5	0.1
14%	2.7	4.7	2.5	0.1
15%	2.4	5.0	2.5	0.1
16%	2.1	5.3	2.5	0.1
17%	1.7	5.7	2.5	0.1

* Resolving Gel Buffer - 1.5 M Tris-HCl, pH 8.8

* Stacking Gel Buffer - 0.5 M Tris-HCl, pH 6.8

2. Immediately prior to pouring the gel, add:

For 10 ml monomer solution:

Resolving Gel: 50 μ l 10% APS and
5 μ l TEMED

Stacking Gel: 50 μ l 10% APS and
10 μ l TEMED

Swirl gently to initiate polymerization.

Note: Prepare any desired volume of monomer solution by using multiples of the 10 ml recipe. The volumes of APS and TEMED must be adjusted accordingly.

Warning: The catalyst concentration is very important! Webbing and incomplete well formation can result from inaccurate catalyst concentration.

4.3 Discontinuous Native PAGE (Ornstein-Davis)²

Stock Solutions and Buffers

1. Acrylamide/Bis (30% T, 2.67% C)

87.6 g acrylamide (29.2 g/100 ml)

2.4 g N'N'-bis-methylene-acrylamide (0.8 g/100 ml)

Make to 300 ml with deionized water. Filter and store at 4 °C in the dark (30 days maximum).

or, use:

Preweighed Acrylamide/Bis, 37.5:1 mixture
(Bio-Rad catalog number 161-0125, 150 g)

30% Acrylamide/Bis Solutions, 37.5:1 mixture
(Bio-Rad catalog number 161-0158, 500 ml)
(Bio-Rad catalog number 161-0159, 2 x 500 ml)

2. 1.5 M Tris-HCl, pH 8.8

27.23 g Tris base (18.15 g/100 ml)

80 ml deionized water

Adjust to pH 8.8 with 6 N HCl. Bring total volume up to 150 ml with deionized water and store at 4 °C. Alternatively 1.5 M Tris-HCl, pH 8.8 (1 L) premixed buffer can be used (Bio-Rad catalog number 161-0798).

3. 0.5 M Tris-HCl, pH 6.8

6 g Tris base

60 ml deionized water

Adjust to pH 6.8 with 6 N HCl. Bring total volume up to 100 ml with deionized water and store at 4 °C. Alternatively 0.5 M Tris-HCl, pH 6.8 (1 L) premixed buffer can be used (Bio-Rad catalog number 161-0799).

4. Sample Buffer

5.55 ml deionized water

1.25 ml 0.5 M Tris-HCl, pH 6.8

3.0 ml glycerol

0.2 ml 0.5% (w/v) bromophenol blue

10.0 ml Total Volume

Store at room temperature.

Use: Dilute the sample at least 1:2 with sample buffer and heat at 95 °C for 4 minutes.

5. 10x Electrode (Running) Buffer, pH 8.3

30.3 g	Tris base	(15 g/l)
144.0 g	Glycine	(72 g/l)

Bring total volume up to 1,000 ml with deionized water. Do not adjust pH. Alternatively electrophoresis running buffer 10x Tris/Glycine, 1 L (Bio-Rad catalog number 161-0734) can be used.

Usage: Dilute 50 ml of 10x stock with 450 ml deionized water for each electrophoresis run.

Gel Formulations (10 ml)

1. Prepare the monomer solution by mixing all reagents except the TEMED and 10% APS. Degas the mixture for 15 minutes.

Percent Gel	DDI H ₂ O (ml)	30% Degassed Acrylamide/Bis (ml)	*Gel Buffer (ml)
4%	6.2	1.3	2.5
5%	5.8	1.7	2.5
6%	5.5	2.0	2.5
7%	5.2	2.3	2.5
8%	4.8	2.7	2.5
9%	4.5	3.0	2.5
10%	4.2	3.3	2.5

* Resolving Gel Buffer - 1.5 M Tris-HCl, pH 8.8

* Stacking Gel Buffer - 0.5 M Tris-HCl, pH 6.8

2. Immediately prior to pouring the gel, add:

50 ml APS and

TEMED (5 µl for Resolving Gels; 10 µl TEMED for stacking gels)

Swirl gently to initiate polymerization.

Note: Prepare any desired volume of monomer solution by using multiples of the 10 ml recipe. The volumes of APS and TEMED must be adjusted accordingly.

4.4 Continuous Native PAGE

Stock Solutions and Buffers

1. Acrylamide/Bis (30% T, 2.67% C)

87.6 g	acrylamide	(29.2 g/100 ml)
2.4 g	N'N'-bis-methylene-acrylamide	(0.8 g/100 ml)

Make to 300 ml with deionized water. Filter and store at 4 °C in the dark (30 days maximum.)

or, use:

Preweighed Acrylamide/Bis, 37.5:1 mixture
(Bio-Rad catalog number 161-0125, 150 g)

30% Acrylamide/Bis Solutions, 37.5:1 mixture
(Bio-Rad catalog number 161-0158, 500 ml)
(Bio-Rad catalog number 161-0159, 2 x 500 ml)

2. Sample Buffer

1.0 ml	Electrophoresis Buffer
3.0 ml	Glycerol
0.2 ml	0.5% Bromophenol Blue
<u>5.8 ml</u>	<u>Deionized water</u>
10.0 ml	Total Volume

3. Continuous Buffers (McLellan)⁴

McLellan describes various continuous buffer systems from pH 3.8 to pH 10.2. Use the table below to prepare 5x continuous non-denaturing PAGE electrophoresis buffers. Add both the acidic and basic component to 1 liter of water. Do not adjust the pH. If the final pH is outside the listed range discard the buffer and remake.

pH	Basic Component	5x Solution	Acidic Component	5x Solution
3.8	Beta-Alanine (89.09 MW)	13.36 g/L	Lactic Acid 85% Solution	7.45 ml/L
4.4	Beta-Alanine (89.09 MW)	35.64 g/L	Acetic Acid 17.4 M	11.5 ml/L
4.8	GABA (103.1 MW)	41.24 g/L	Acetic Acid 17.4 M	5.75 ml/L
6.1	Histidine (155.2 MW)	23.28 g/L	MES (195.2 MW)	29.5 g/L
6.6	Histidine (155.2 MW)	19.4 g/L	MOPS (209.3 MW)	31.4 g/L
7.4	Imidazole (68.08 MW)	14.64 g/L	HEPES (238.33 MW)	41.7 g/L
8.1	Tris (121.14 MW)	19.38 g/L	EPPS (252.2 MW)	37.85 g/L
8.7	Tris (121.14 MW)	30.29 g/L	Boric Acid (61.83 MW)	7.73 g/L
9.4	Tris (121.14 MW)	36.34 g/L	CAPS (221.3 MW)	44.26 g/L
10.2	Ammonia (14.8 M)	12.5 ml/L	CAPS (221.3 MW)	22.13 g/L

Dilute 200 ml of 5x buffer with 800 ml deionized water to prepare 1x electrophoresis buffer. The final concentrations of buffer components will be.

pH	Basic Component	Acidic Component
3.8	30 mM Beta-Alanine	20 mM Lactic Acid
4.4	80 mM Beta-Alanine	40 mM Acetic Acid
4.8	80 mM GABA	20 mM Acetic Acid
6.1	30 mM Histidine	30 mM MES
6.6	25 mM Histidine	30 mM MOPS
7.4	43 mM Imidazole	35 mM HEPES
8.1	32 mM Tris	30 mM EPPS
8.7	50 mM Tris	25 mM Boric Acid
9.4	60 mM Tris	40 mM CAPS
10.2	37 mM Ammonia	20 mM CAPS

Gel Formulations (10 ml)

1. Prepare the monomer solution by mixing all reagents except the TEMED and 10% APS. Degas the mixture for 15 minutes.

Percent Gel	DDI H ₂ O (ml)	30% Degassed Acrylamide/Bis (ml)	Continuous Buffer (ml)
4%	6.7	1.3	2.0
5%	6.3	1.7	2.0
6%	6.05	2.0	2.0

Note: Prepare any desired volume of monomer solution by using multiples of the 10 ml recipe.

2. Immediately prior to pouring the gel, add:

For 10 ml monomer solution:

50 μ l 10% APS

10 μ l TEMED

Swirl gently to initiate polymerization.

Note: Below pH 6, TEMED becomes a less effective catalyst. Increase the concentration of TEMED 5-fold to polymerize gels with a pH range between 4 and 6.

Section 5 References

1. Laemmli, U. K., *Nature*, **227**, 680 (1970).
2. Ornstein, L. and Davis, B. J., *Anal. NY Acad. Sci.*, **121**, 321 (1964).
3. Chrambach, A. and Jovin, T. M., *Electrophoresis*, **4**, 190–204 (1984).
4. McLellan, T., *Analytical Biochemistry*, **126**, 94–99 (1982).

Section 6 Maintenance

Mini-PROTEAN 3 tank and lid, electrode assembly, clamping frame	Rinse thoroughly with distilled water after every use.
Casting stand and frame	Rinse thoroughly with distilled water after every use.
Glass plates and combs	Wash with a laboratory detergent, then rinse thoroughly with distilled water. Limit submersion of Spacer Plates in strongly basic solutions, such as >100 mM NaOH, to less than 24 hours. Limit submersion in chromic-sulfuric acid glass cleaning solution to 2–3 hours. Prolonged submersion compromises the integrity of the adhesive. To preserve the longevity of the adhesive bond, avoid extended submersion (>5 days) in cleaning solutions made from Bio-Rad cleaning concentrate (161-0722) or other strongly basic detergents.

Section 7

Troubleshooting Guide

Problem	Cause	Solution
1. "Smile effect" - band pattern curves upward at both sides of the gel.	a. Center of the gel running hotter than either end.	a. Buffer not mixed well or buffer in upper chamber too concentrated. Remake buffer, insuring thorough mixing, especially when diluting 5x or 10x stock.
	b. Power conditions excessive.	b. Decrease power setting from 200 V to 150 V or fill lower chamber to within 1 cm of top of Short Plate.
2. Vertical streaking of protein.	a. Sample overload.	a. Dilute sample, selectively remove predominant protein in the sample, or reduce voltage by about 25% to minimize streaking.
	b. Sample precipitation.	b. Centrifuge sample before addition of SDS sample buffers, or decrease % T of resolving gel.*
		c. The ratio of SDS to protein should be enough to coat each protein molecule with SDS, generally 1.4:1. It may require more SDS for some membrane protein samples. For example, SDS in sample can be increased to 4% and/or in running buffer increased to 0.4%.
3. Lateral band spreading.	a. Diffusion out of the wells prior to turning on the current	a. Minimize the time between sample application and power start up.
	b. Ionic strength of sample lower than that of gel.	b. Use same buffer in sample as in gel or stacking gel.
4. Skewed or distorted bands.	a. Poor polymerization around sample wells.	a. Degas stacking gel solution thoroughly prior to casting; increase ammonium persulfate and TEMED concentrations by 25%; for stacking gel or low%T, leave APS the same and double the TEMED concentration.
	b. Salts in sample.	b. Remove salts by dialysis, desalting column, Micro Bio-Spin columns, etc.
	c. Uneven gel interface.	c. Decrease the polymerization rate. Overlay gels very carefully.
5. Lanes constricted at bottom of gel.	a. Ionic strength of sample higher than that of surrounding gel.	a. Desalt sample and neighboring samples.
6. Run taking unusually long time.	a. Running buffer too concentrated.	a. Check buffer protocol, dilute if necessary.
	b. Excessive salt in sample.	b. Desalt sample.

Problem	Cause	Solution
7. Run too fast, poor resolution.	a. Running or reservoir buffer too dilute. b. Voltage too high.	a. Check buffer protocol, concentrate if necessary. b. Decrease voltage by 25–50%.
8. Doublets observed where a single protein species is expected (SDS-PAGE)	a. A portion of the protein may have been reoxidized during the run or may not have been fully reduced prior to run.	a. Prepare fresh sample buffer solutions if over 30 days old; increase 2-mercaptoethanol concentration in the sample buffer; substitute DTT for BME.
9. Observe fewer bands than expected and one heavy band at dye front.	a. Protein(s) migrating at the dye front. b. Protein degradation.	a. Increase % T of resolving gel.* b. Use protease inhibitors, e.g. PMSF, etc.
10. Upper buffer chamber leaks.	a. Upper buffer chamber over filled. b. Improper assembly.	a. Keep level of buffer below the top of the Spacer Plates. b. Be sure u-shaped electrode core gasket is clean, free of cuts, and lubricated with buffer. Be sure Short Plate is <i>under</i> the notch on the gasket, not on top of it and press down on electrode assembly when closing cams of the frame.
11. Leaking during gel casting.	a. Chipped glass plates. b. Spacer Plate and Short Plate not level. c. Casting Stand gasket is flawed or worn out.	a. Insure glass plates are free of flaws. b. Insure cassette is aligned correctly. c. Replace casting stand gaskets.
12. Poor end well formation.	a. Incorrect catalyst concentration. b. Monomer solution not degassed. Oxygen inhibits polymerization.	a. Prepare fresh catalyst solution, or increase catalyst concentration of stacking gel to 0.06% APS and 0.12% TEMED. b. Degas monomer solution immediately prior to casting the stacking gel.
13. Webbing/excess acrylamide behind the comb.	a. Incorrect catalyst concentration.	a. Prepare fresh catalyst solution, or increase catalyst concentration of stacking gel to 0.06% APS and 0.12% TEMED.
14. The pressure cams on the casting frame are difficult to close or make a noise when closed.	a. A build up of a powder residue at the pivot point of the pressure cams.	a. Rinse or wipe off the powder residue before each use.

*Polyacrylamide gels are described by reference to two characteristics:

- 1) The total monomer concentration, (%T) and
- 2) The crosslinking monomer concentration (%C).

$$\frac{\text{g acrylamide} + \text{g bis-acrylamide}}{\text{Total Volume}} \times 100\%$$

$$\frac{\text{g bis-acrylamide}}{\text{g acrylamide} + \text{g bis-acrylamide}} \times 100\%$$

Section 8 Product Information and Accessories

Catalog Number	Description
Mini PROTEAN 3 Systems	
165-3301	Mini-PROTEAN 3 Electrophoresis System , 10 well, 0.75 thickness, complete system includes 2 combs, 5 sets of glass plates, casting stand, 2 casting frames, sample loading guide, 2 gel releasers, and Electrophoresis Module
165-3302	Mini-PROTEAN 3 Electrophoresis Module , for Ready Gel precast gel applications, includes electrode assembly, clamping frame, tank, lid with power cables, mini cell buffer dam, 2 gel releasers
165-3375	Mini-PROTEAN II Upgrade Kit , includes Mini-PROTEAN 3 Clamping Frame and Electrode Assembly
165-3314	Mini-PROTEAN 3 Cell/PowerPac 300 System , 100/120 V
165-3315	Mini-PROTEAN 3 Cell/PowerPac 300 System , 220/240 V
165-3316	Mini-PROTEAN 3 Cell/PowerPac Junior System , 100–240 V
165-3317	Mini-PROTEAN 3 Cell and Mini Trans-Blot® module

Casting Modules

Each casting module includes 2 combs, 5 sets of glass plates, casting stand, 2 casting frames, and the appropriate Sample Loading Guide.

	0.5 mm spacer	0.75 mm spacer	1.0 mm spacer	1.5 mm spacer
5 well comb	NA	165-3327	165-3332	165-3338
9 well comb	NA	165-3328	165-3333	165-3339
10 well comb	165-3325	165-3329	165-3334	165-3340
15 well comb	165-3326	165-3330	165-3335	165-3341
Prep/2D comb	NA	165-3331	165-3336	165-3342
IPG comb	NA	NA	165-3337	165-3343

Hand Cast Gel Accessories and Replacement Parts

165-3303	Mini-PROTEAN 3 Casting Stand , 1
165-3304	Mini-PROTEAN 3 Casting Frame , 1
165-3305	Mini-PROTEAN 3 Casting Stand Gaskets (replacement) , 2
165-3308	Mini-PROTEAN 3 Short Plates , 5
165-3309	Mini-PROTEAN 3 Spacer Plates with 0.5 mm spacers , 5
165-3310	Mini-PROTEAN 3 Spacer Plates with 0.75 mm spacers , 5
165-3311	Mini-PROTEAN 3 Spacer Plates with 1.0 mm spacers , 5
165-3312	Mini-PROTEAN 3 Spacer Plates with 1.5 mm spacers , 5

Catalog Number	Description
Other Replacement Parts	
165-3306	Mini-PROTEAN 3 Clamping Frame , 1
165-3307	Mini-PROTEAN 3 Electrode Assembly , 1
165-3201	Sample Loading Guide, 9 well (red) , 1
165-3146	Sample Loading Guide, 10 well (yellow) , 1
165-3203	Sample Loading Guide, 12 well (green) , 1
165-3132	Sample Loading Guide, 15 well (blue) , 1
165-3130	Buffer Dam , 2
165-3320	Mini PROTEAN 3 Gel Releaser , 5
165-3149	Replacement Electrode Assembly Gaskets , 2
165-3157	Gaskets, for precast carbohydrate gels , 2
161-0990	Empty Cassettes, 1.0 mm Ready Gel , 10
165-2975	Buffer Tank and Lid , replacement
165-2948	Replacement Power Cables
165-2949	Cell Lid with Power Cables
900-7680-8	Replacement Platinum Wire, cathode , 8 inches
900-7680-13	Replacement Platinum Wire, anode , 13 inches

Combs

	0.5 mm spacer	0.75 mm spacer	1.0 mm spacer	1.5 mm spacer
5 well comb	NA	165-3352	165-3357	165-3363
9 well comb	NA	165-3353	165-3358	165-3364
10 well comb	165-3350	165-3354	165-3359	165-3365
15 well comb	165-3351	165-3355	165-3360	165-3366
Prep/2D comb	NA	165-3356	165-3361	165-3367
IPG comb	NA	NA	165-3362	165-3368

Section 9

Warranty Information

The Mini-PROTEAN 3 cell is warranted for 1 year against defects in materials and workmanship. If any defects should occur during this warranty period, Bio-Rad Laboratories will replace the defective parts without charge. However the following defects are specifically excluded.

1. Defects caused by improper operation.
2. Repairs or modifications done by anyone other than Bio-Rad Laboratories or their authorized agent.
3. Damaged caused by accidental misuse.
4. Damage caused by disaster.
5. Common consumable replacement parts including platinum wire, the rubber gaskets, and glass plates.
6. Damage caused by the use of organic solvents.

For inquiry or request for repair service, contact your local Bio-Rad office.

Warranty Information

Model _____

Catalog Number _____

Date of Delivery _____

Serial Number _____

Invoice Number _____

Purchase Order No _____



**Bio-Rad
Laboratories, Inc.**

Life Science
Group

Web site www.bio-rad.com **Bio-Rad Laboratories Main Office** 2000 Alfred Nobel Drive, Hercules, CA 94547, Ph. (510) 741-1000, Fx. (510) 741-5800
Also in: **Australia** Ph. 02 9914 2800, Fx. 02 9914 2889 **Austria** Ph. (01) 877 89 01, Fx. (01) 876 56 29 **Belgium** Ph. 09-385 55 11, Fx. 09-385 65 54
Brazil Ph. 55 21 507 6191 **Canada** Ph. (905) 712-2771, Fx. (905) 712-2990 **China** Ph. 86-10-8201-1366/68, Fx. 86-10-8201-1367
Denmark Ph. 45 44 52-1000, Fx. 45 4452 1001 **Finland** Ph. 358 (0)9 804 2200, Fx. 358 (0)9 804 1100 **France** Ph. 01 47 95 69 65, Fx. 01 47 41 9133
Germany Ph. 089 318 84-177, Fx. 089 318 84-123 **Hong Kong** Ph. 852-2789-3300, Fx. 852-2789-1257 **India** Ph. (91-124)-6398112/113/114, Fx. (91-124)-6398115
Israel Ph. 03 951 4124, Fx. 03 951 4129 **Italy** Ph. 34 91 590 5200, Fx. 34 91 590 5211 **Japan** Ph. 03-5811-6270, Fx. 03-5811-6272
Korea Ph. 82-2-3473-4460, Fx. 82-2-3472-7003 **Latin America** Ph. 305-894-5950, Fx. 305-894-5960 **Mexico** Ph. 52 5 534 2552 to 54, Fx. 52 5 524 5971
The Netherlands Ph. 0318-540666, Fx. 0318-542216 **New Zealand** Ph. 64-9-4152280, Fx. 64-9-443 3097 **Norway** Ph. 47-23-38-41-30, Fx. 47-23-38-41-39
Russia Ph. 7 095 979 98 00, Fx. 7 095 979 98 56 **Singapore** Ph. 65-2729877, Fx. 65-2734835 **Spain** Ph. 34-91-590-5200, Fx. 34-91-590-5211
Sweden Ph. 46 (0)8-55 51 27 00, Fx. 46 (0)8-55 51 27 80 **Switzerland** Ph. 061-717-9555, Fx. 061-717-9550 **United Kingdom** Ph. 0800-181134, Fx. 01442-259118

Sig 0101

4006157 Rev B